

Type: Wear resistant submersible mixer
 Application: Prevent the accumulation of solids and floating crusts.

Mixer

Effective area up to 6m
 Impeller diameter 150 mm
 Electrical power in clean water 1.8 kW
 Weight 43 kg

Motor

Mains: 50Hz – 3 phase
 Rated shaft power (P2) 1.5 kW
 Absorbed electrical power (P1) 2.1 kW
 Nominal speed 1420 rpm
 Motor efficiency 71 %
 Power factor (cos phi) 0.84
 Degree of protection IP 68
 Isolation class F (155°C)
 Max. water temperature 40°C
 Standard cable length 10 m



Materials

Impeller Nihard 4 (G-X300CrNiSi 9 5)
 Motor unit parts Cast iron GG 25 (EN-GJL-250)
 Pump shaft AISI 431 (X20 CrNi 17 2)
 Alt: AISI 316 (X5 CrNiMo 17 12 2)
 Pump support Fe 37
 Alt: RVS 316 (X5 CrNiMo 17 12 2)
 Bolts AISI 316 (X5 CrNiMo 17 12 2)
 Rubber parts Nitrile (NBR) or neoprene (CR)
 Alt: viton (FPM)
 Electrical cable Neoprene (CR)
 Seal lubrication Oil
 Seal pump side Silicon carbide – silicon carbide
 Seal motor side Carbon - ceramic
 Coating Two component polyurethane

Optional

- Flameproof version, to class:
 Standard: II 2 G Ex b c d IIB T4 Gb
 With Frequency control: II 2 G Ex b c d IIB T3 Gb
- Thermo switches in motor windings
 (standard for flameproof version)
- Cable protection sheet (AISI316)
- Water detector in motor en oil chamber
 Flameproof version with external cable

Dimensions mm

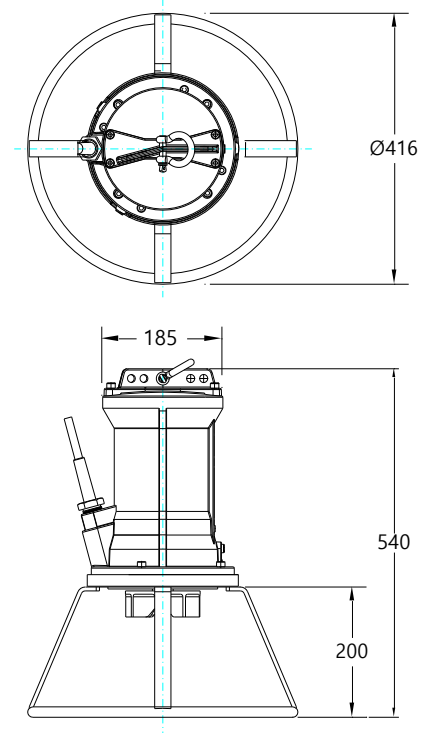

Connections

voltage	current	electrical cable size		motor protection and/or water detector		flameproof version		
		direct start		direct start		direct start		
230	6.3	4G1.5		7G1.5		7G1.5		
400	3.6	4G1.5		7G1.5		7G1.5		
500	2.9	4G1.5		7G1.5		7G1.5		
starting current DOL start : 4.8 x rated current								
							* other voltages on request	