

Type: Wear Resistant Submersible mixer
 Application: Prevent the accumulation of solids and floating crusts.

Mixer

Effective area up to 14m
 Impeller diameter 190
 Electrical power in clean water 7.1 kW
 Weight 88 kg

Motor

Mains: 50Hz – 3 phase
 Rated shaft power (P2) 7.5 kW
 Absorbed electrical power (P1) 9.3 kW
 Nominal speed 1390 rpm
 Motor efficiency 78 %
 Power factor (cos phi) 0.88
 Degree of protection IP 68
 Isolation class F (155°C)
 Max. water temperature 40°C
 Standard cable length 10 m

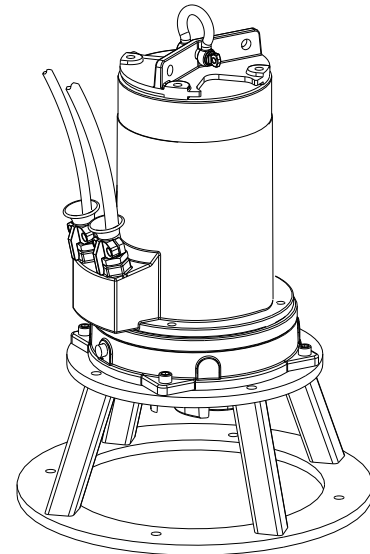

Materials

Impeller Nihard 4 (G-X300CrNiSi 9 5)
 Motor unit parts Cast iron GG 25 (EN-GJL-250)
 Pump shaft AISI 431 (X20 CrNi 17 2)
 Alt: AISI 316 (X5 CrNiMo 17 12 2)
 Pump support Fe 37
 Alt: RVS 316 (X5 CrNiMo 17 12 2)
 Bolts AISI 316 (X5 CrNiMo 17 12 2)
 Rubber parts Nitrile (NBR) or neoprene (CR)
 Alt: viton (FPM)
 Electrical cable Neoprene (CR)
 Seal lubrication Oil
 Seal pump side Silicon carbide – silicon carbide
 Seal motor side Carbon - ceramic
 Coating Two component polyurethane

Optional

- Flameproof version, to class:
 Standard: II 2 G Ex b c d IIB T4 Gb
 With Frequency control: II 2 G Ex b c d IIB T3 Gb
- Thermoswitches in motor windings
 (standard for flameproof version)
- Cable protection sheet (AISI316)
- Water detector in motor and oil chamber
 Flameproof version with external cable

Dimensions mm

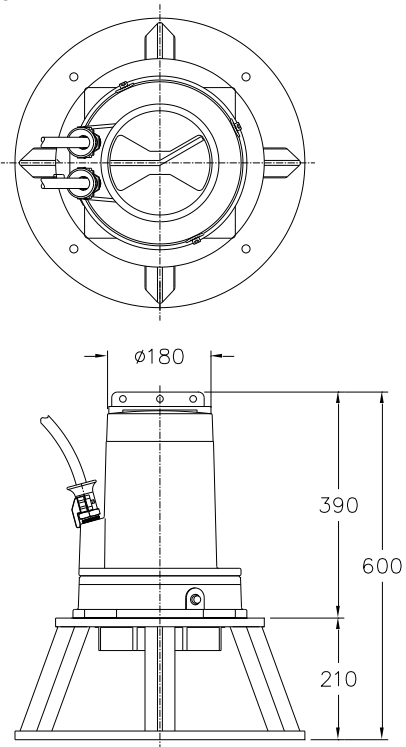

Connections

| voltage | current | electrical cable size | | motor protection and/or water detector | | flameproof version | |
|--------------------------------------------------|---------|-----------------------|-----------------|----------------------------------------|-----------------|--------------------|-----------------|
| | | direct start | stardelta start | direct start | stardelta start | direct start | stardelta start |
| 230 | 26.4 | 4G6 | 7G2.5 | 4G6 + 4G1.5 | 7G2.5 + 4G1.5 | 4G6 + 4G2.5 | 7G2.5 + 4G2.5 |
| 400 | 15.2 | 4G2.5 | 7G1.5 | 7G1.5 | 12G1.5 | 7G1.5 | 12G1.5 |
| 500 | 12.1 | 4G2.5 | 7G1.5 | 7G1.5 | 12G1.5 | 7G1.5 | 12G1.5 |
| starting current DOL start : 6.1 x rated current | | | | | | | |
| starting current YD start : 2.0 x rated current | | | | * other voltages on request | | | |