

Type: Submersible mixer  
 Application: Prevent the accumulation of solids and floating crusts.

## Mixer

Effective area up to Ø6m  
 Impeller diameter 115mm  
 Electrical power in clean water 1.8 kW  
 Weight 44 kg

## Motor

Mains: 50Hz – 3 phase  
 Rated shaft power (P2) 1.5 kW  
 Absorbed electrical power (P1) 2.1 kW  
 Nominal speed 1420 rpm  
 Motor efficiency 71 %  
 Power factor (cos phi) 0.84  
 Degree of protection IP 68  
 Isolation class F (155°C)  
 Max. water temperature 40°C  
 Standard cable length 10 m



## Materials

Impeller AISI 329  
 Motor unit parts AISI 329  
 Pump shaft AISI 316  
 Pump support AISI 316  
 Bolts AISI 316  
 Rubber parts Viton (FPM)  
 Electrical cable Neoprene (CR)  
 Seal lubrication Oil  
 Seal pump side Silicon carbide – silicon carbide-Viton  
 Seal motor side Carbon - ceramic

## Optional

- Flameproof version, to class: II 2 G Ex d IIB c T4  
 Standard: II 2 G Ex b c d IIB T4 Gb  
 With Frequency control: II 2 G Ex b c d IIB T3 Gb
- Thermo switches in motor windings (standard for flameproof version)
- Cable protection sheet (AISI316)
- Water detector in motor and oil chamber  
 Flameproof version with external cable
- Heavy duty support (AISI316)

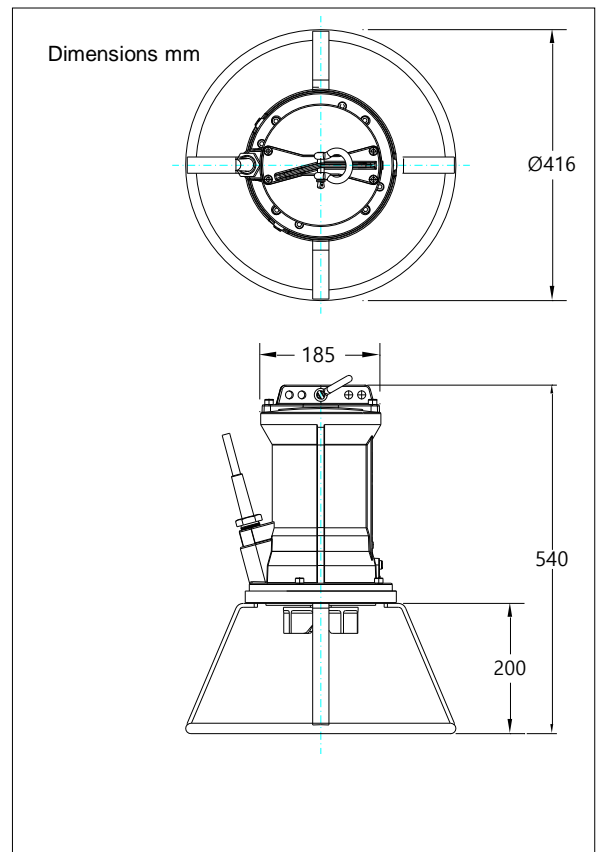

## Connections

voltage	current	electrical cable size		motor protection and/or water detector		flameproof version		
		direct start		direct start		direct start		
230	6.3	4G1.5		7G1.5		7G1.5		
400	3.6	4G1.5		7G1.5		7G1.5		
500	2.9	4G1.5		7G1.5		7G1.5		
starting current DOL start : 4.8 x rated current								
							* other voltages on request	