

Type: Submersible mixer
 Application: Prevent the accumulation of solids and floating crusts.

Mixer

Effective area up to Ø8m
 Impeller diameter 125mm
 Electrical power in clean water 2.5 kW
 Weight 44 kg

Motor

Mains: 50Hz – 3 phase
 Rated shaft power (P2) 2.2 kW
 Absorbed electrical power (P1) 3.1 kW
 Nominal speed 1375 rpm
 Motor efficiency 71 %
 Power factor (cos phi) 0.89
 Degree of protection IP 68
 Isolation class F (155°C)
 Max. water temperature 40°C
 Standard cable length 10 m



Materials

Impeller AISI 329
 Motor unit parts AISI 329
 Pump shaft AISI 316
 Pump support AISI 316
 Bolts AISI 316
 Rubber parts Viton (FPM)
 Electrical cable Neoprene (CR)
 Seal lubrication Oil
 Seal pump side Silicon carbide – silicon carbide-Viton
 Seal motor side Carbon - ceramic

Optional

- Flameproof version, to class: II 2 G Ex d IIB c T4
 Standard: II 2 G Ex b c d IIB T4 Gb
 With Frequency control: II 2 G Ex b c d IIB T3 Gb
- Thermo switches in motor windings (standard for flameproof version)
- Cable protection sheet (AISI316)
- Water detector in motor and oil chamber
 Flameproof version with external cable
- Heavy duty support (AISI316)

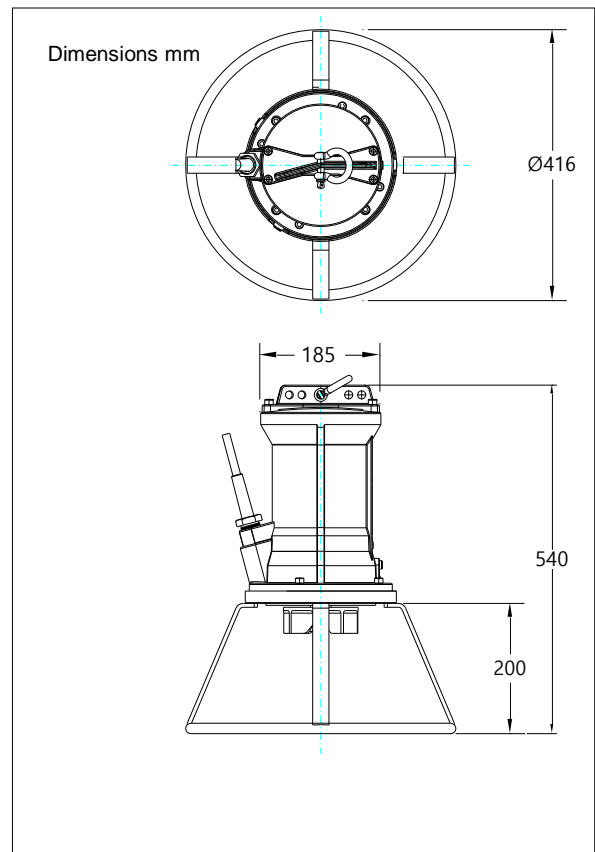

Connections

voltage	current	electrical cable size		motor protection and/or water detector		flameproof version	
		direct start	star-delta start	direct start	star-delta start	direct start	star-delta start
230	8.7	4G1.5	7G1.5	7G1.5	12G1.5	7G1.5	12G1.5
400	5.0	4G1.5	7G1.5	7G1.5	12G1.5	7G1.5	12G1.5
500	4.0	4G1.5	7G1.5	7G1.5	12G1.5	7G1.5	12G1.5
starting current DOL start : 3.4 x rated current							
starting current YD start : 1.1 x rated current						* other voltages on request	