

Type: Submersible mixer
 Application: Preventing the accumulation of solids and floating crusts.

Mixer

Effective area up to 18m
 Impeller diameter 173
 Electrical power in clean water 13.5 kW
 Weight 102 kg

Motor

Mains: 50Hz – 3 phase
 Rated shaft power (P2) 13.0 kW
 Absorbed electrical power (P1) 15.1 kW
 Nominal speed 1420 rpm
 Motor efficiency 86 %
 Power factor (cos phi) 0.84
 Degree of protection IP 68
 Isolation class F (155°C)
 Max. water temperature 40°C
 Standard cable length 10 m

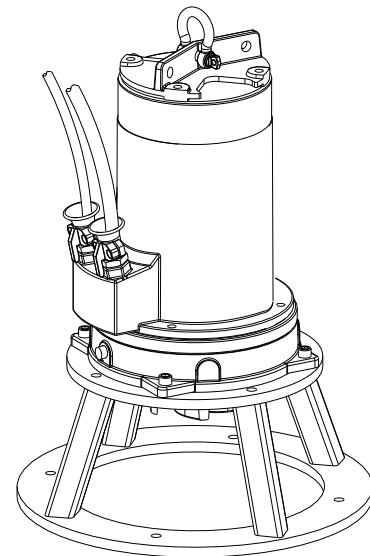

Materials

Impeller S.g cast iron GGG 40 (EN-GJS-400-15)
 Motor unit parts Cast iron GG 25 (EN-GJL-250)
 Pump shaft AISI 431 (X20 CrNi 17 2)
 Alt: AISI 316 (X5 CrNiMo 17 12 2)
 Pump support Fe 37
 Alt: RVS 316 (X5 CrNiMo 17 12 2)
 Bolts AISI 316 (X5 CrNiMo 17 12 2)
 Rubber parts Nitrile (NBR) or neoprene (CR)
 Alt: viton (FPM)
 Electrical cable Neoprene (CR)
 Seal lubrication Oil
 Seal pump side Silicon carbide – silicon carbide
 Seal motor side Carbon - ceramic
 Coating Two component polyurethane

Optional

- Flameproof version, to class: II 2 G Ex d IIB c T4
 Standard: II 2 G Ex b c d IIB T4 Gb
 With Frequency control: II 2 G Ex b c d IIB T3 Gb
- Thermoswitches in motor windings
 (standard for flameproof version)
- Cable protection sheet (AISI316)
- Water detector in motor and oil chamber
 Flameproof version with external cable

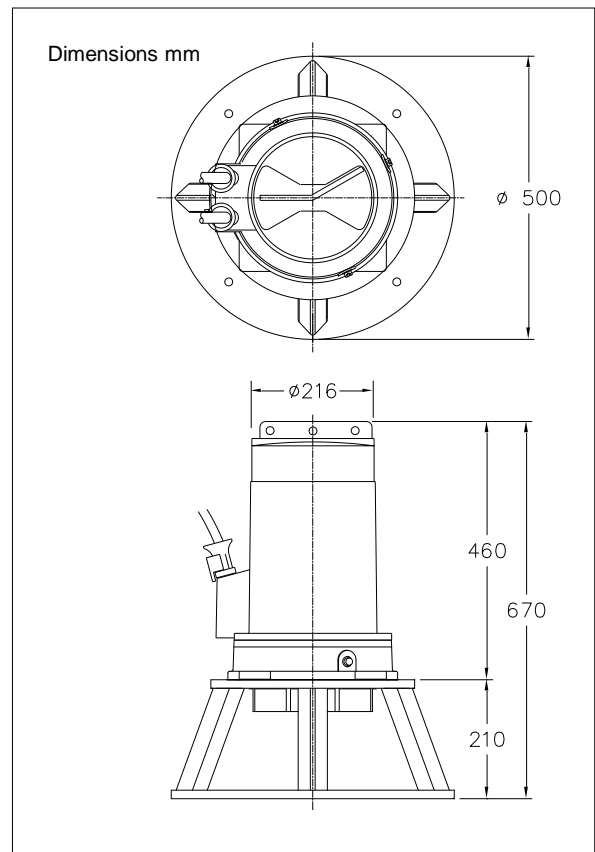

Connections

voltage	current	electrical cable size		motor protection and/or water detector		flameproof version	
		directe start	ster-driehoek start	directe start	ster-driehoek start	directe start	ster-driehoek start
230	45.4	4G10	2x4G6	4G10 + 4G1.5	-	4G10 + 4G2.5	-
400	26.1	4G6	7G1.5	4G6 + 4G1.5	7G2.5 + 4G1.5	4G6 + 4G2.5	7G2.5 + 4G2.5
500	20.9	4G6	7G1.5	4G6 + 4G1.5	12G1.5	4G6 + 4G2.5	12G1.5
starting current DOL start : 5.0 x rated current							
starting current YD start : 1.7 x rated current						* other voltages on request	